



INFOTECH
automation

INFOTECH
automation

INFOTECH
automation

INFOTECH
automation

2024

INFOTECH

FIRMEN PRÄSENTATION



- 1 FIRMENÜBERBLICK
- 2 PRODUKTE
- 3 ANWENDUNGSBEISPIELE

2024

INFOTECH

FIRMEN PRÄSENTATION



- 1 FIRMENÜBERBLICK**
- 2 PRODUKTE
- 3 ANWENDUNGSBEISPIELE

WAS WIR MACHEN

Infotech entwickelt, produziert und liefert höchst präzise Positioniersysteme für eine zuverlässige Prozessautomation – von Einzelanlagen bis zu umfassenden Bestückungslinien

Infotech Komponentenmatrix mit über 1000 Modulen

PLATTFORMEN – KOPF- / TISCH- / ZUFÜHRPERIPHERIEN

100% ENTWICKLUNG IN DER SCHWEIZ

95% HERSTELLUNG IN DER SCHWEIZ

> 2280 INSTALLATIONEN WELTWEIT





GESCHICHTE

- Technisch orientiertes Unternehmen mit Hauptsitz in Solothurn in der Schweiz
- Gründung 1984, aktiv seit 40 Jahren mit 197 Mitarbeitenden
- International agierendes Unternehmen mit Gesamt-Bestückungsanlagen für Schlüsselkunden
- Fast 40 Jahre Erfahrung in der Entwicklung von Automations-Software, in Konstruktion und in der Prozessentwicklung für Halbleiter- und Elektronik-Hybridmontageprozesse
- Seit 2007 Montageprozesse für die Leistungselektronik – ermöglicht ganzheitliche Lösungen

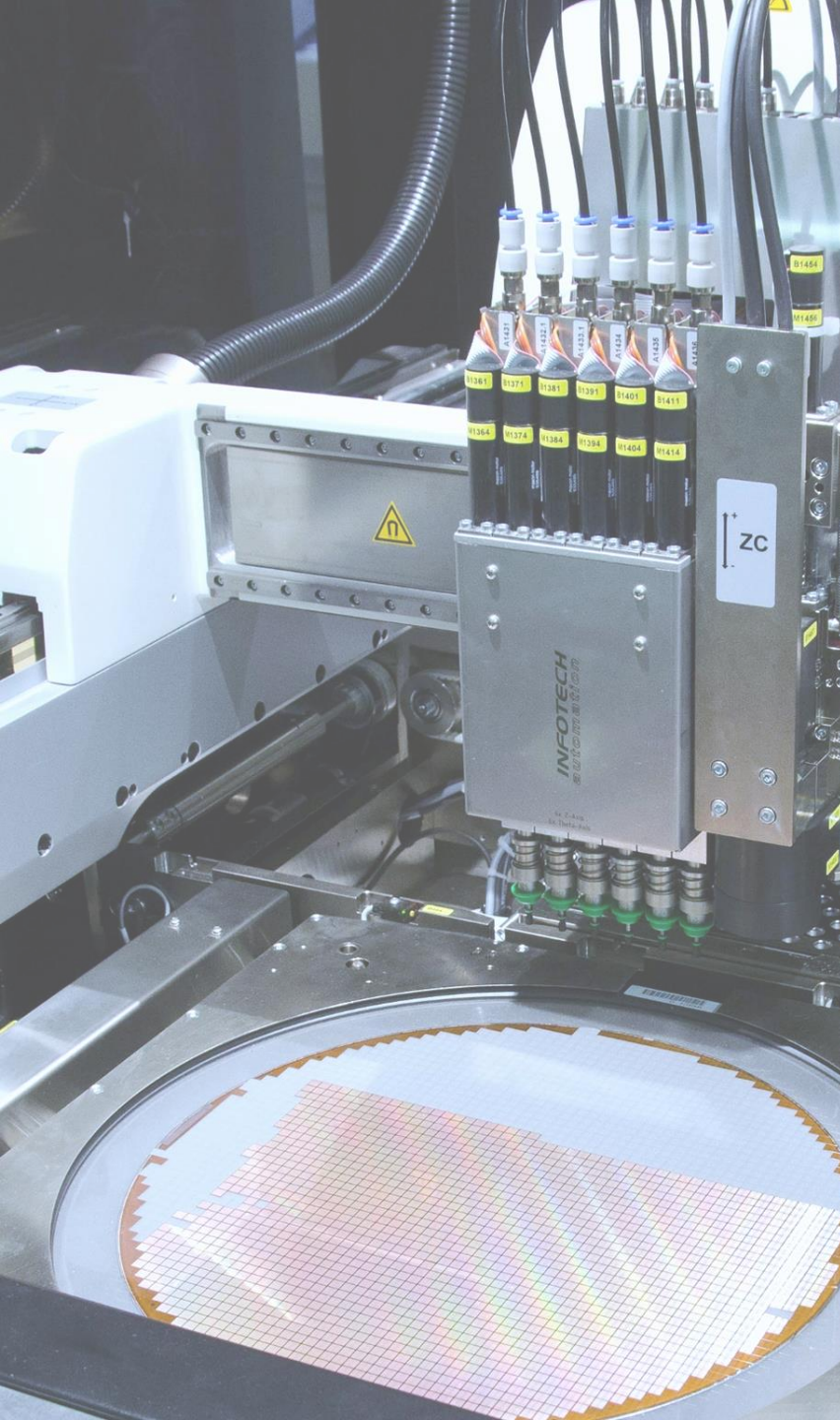

STRATEGIE

- Analysiert die Spezifikationen des Kundenprozesses und generiert zusammen mit dem Kunden ein optimiertes Konzept
- Konfiguriert gesamtheitliche Lösungen basierend auf der Infotech Komponentenmatrix, mit welcher zusätzliche Werte generiert werden und die totalen Betriebskosten einer Anlage oder einer Gesamtlinie über den gesamten Lebenszyklus reduziert werden können
- Fokussiert die Zusammenarbeit mit selektierten Kunden, welche vorausplanend den Lieferanten fair behandeln und verstehen, dass ihre Produkte mit den Infotech Anlagen effizienter realisiert werden können

INFOTECH IN ZAHLEN

100%

Entwicklung bei
Infotech

>95%

Produktion in
der Schweiz

40

Jahre
Infotech AG

>2280

Installationen
weltweit

1056

Jahre Erfahrung in
der Automation

197

Angestellte

>40

Support Ingenieure
weltweit

>50%

Ingenieure

>20

Länder



GESCHICHTE

Eintrag
Handelsregister

1984

Desktopanlagen,
Komponentenmatrix

2001



Produktionslinien

2007

Erste Montagelinie in
der Pharmaindustrie

2015



Hybrid Bonder: Die
Bonding und SMD
Bestückung

2020

>2'280 Anlagen
geliefert
Entwicklung
diverser
Puffermodule

2023

1999

Neupositionierung der
Infotech in Solothurn

INFOTECH
automation

2003

Produktionszellen



2009

Vollautomatische
Uhrwerksmontagelinie

2017

Vollautomatische
Leistungsdioden
Produktionslinie mit
12" Wafer Bonder



2021

3D Druck Anlage
für multimaterial
Designs



2023

Gründung
Infotech
Automation
Inc., USA



ORGANISATION

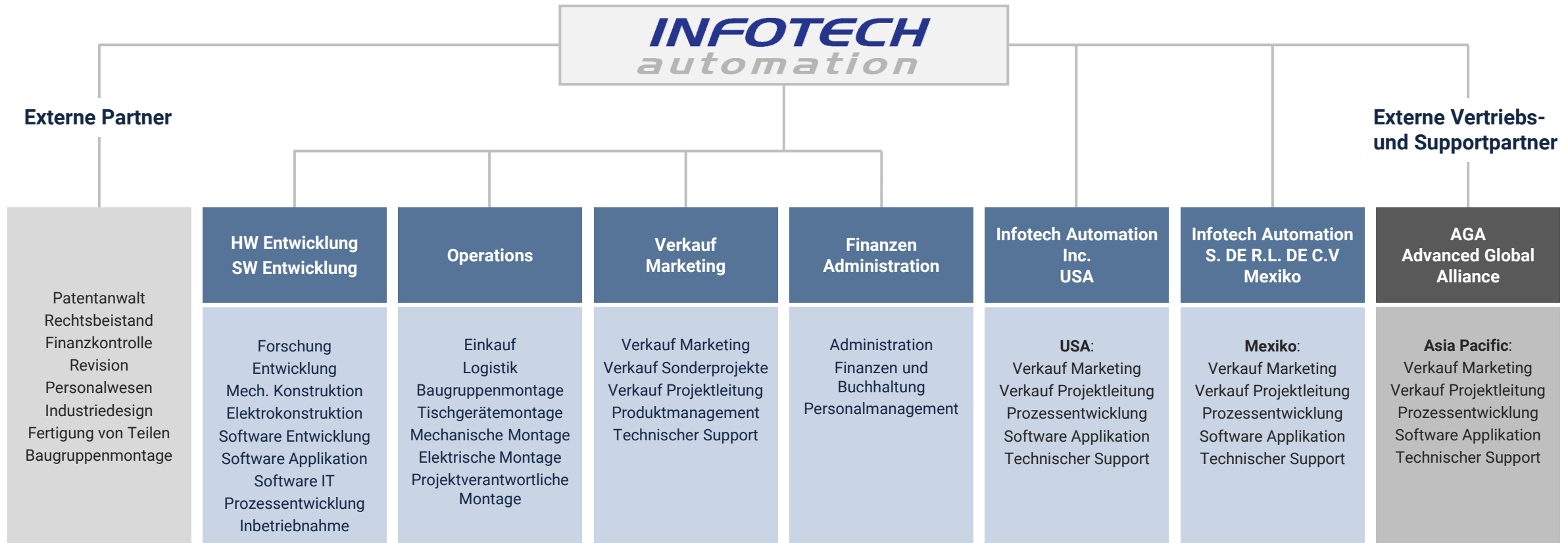

Externe Partner:
Aktivitäten mit externen Firmen
und Lieferanten in der Region Solothurn

Technologiepartner:



STANDORT HAUPTSITZ SCHWEIZ

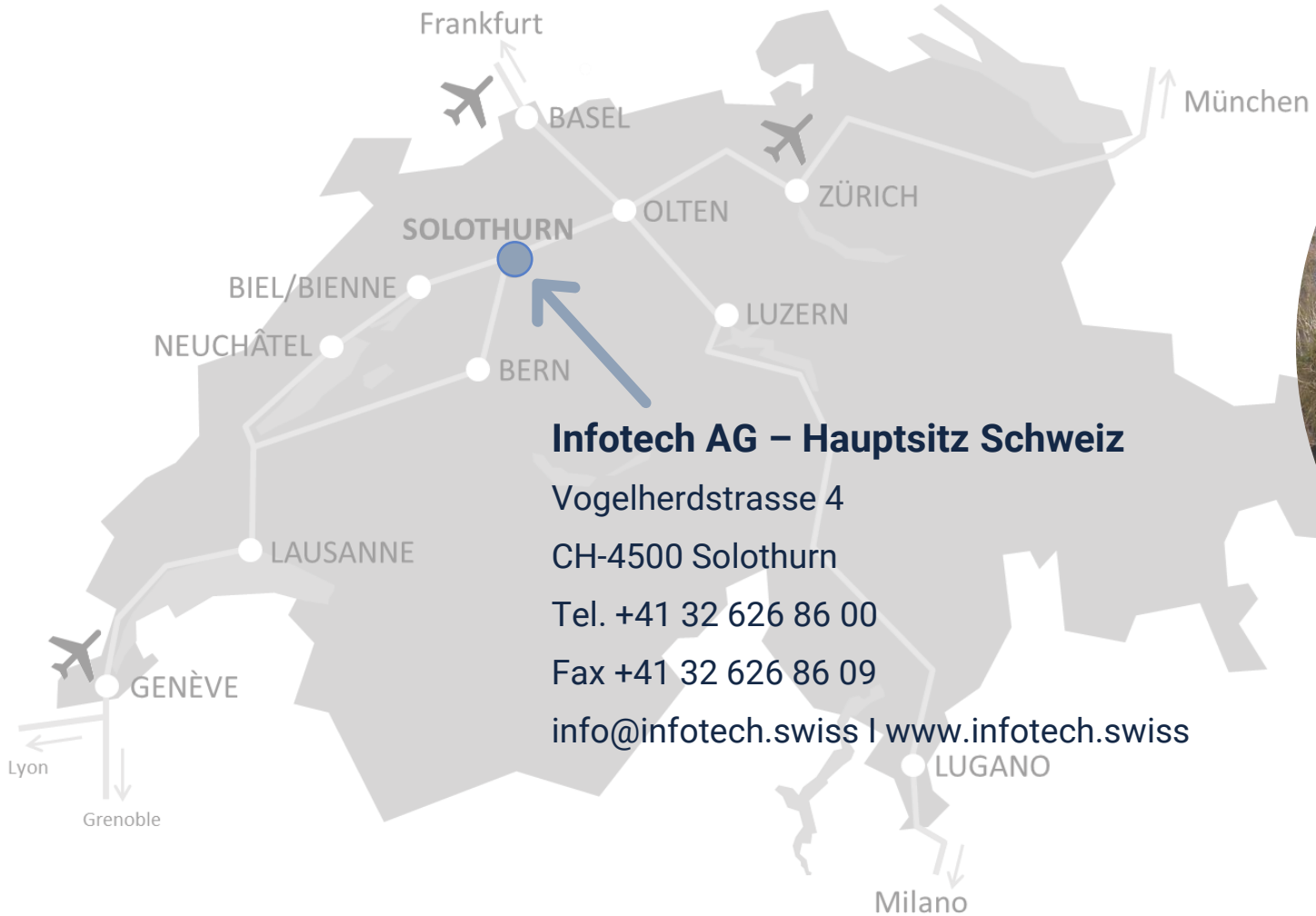

Infotech AG – Hauptsitz Schweiz

Vogelherdstrasse 4

CH-4500 Solothurn

Tel. +41 32 626 86 00

Fax +41 32 626 86 09

info@infotech.swiss | www.infotech.swiss



STANDORTE INTERNATIONAL

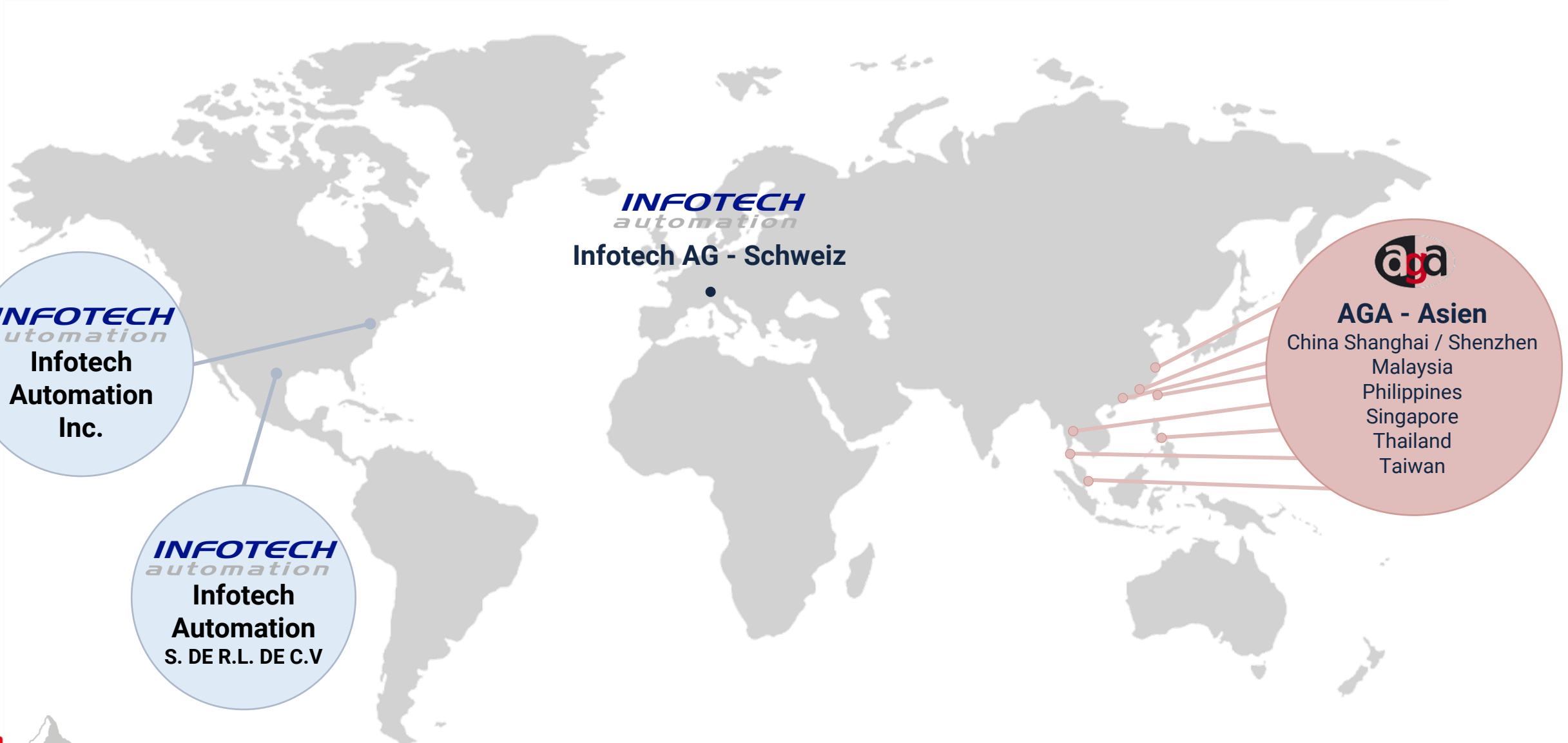

REFERENZEN



2024

INFOTECH

FIRMEN PRÄSENTATION



- 1 FIRMENÜBERBLICK
- 2 PRODUKTE**
- 3 ANWENDUNGSBEISPIELE

INFOTECH KOMPONENTENMATRIX

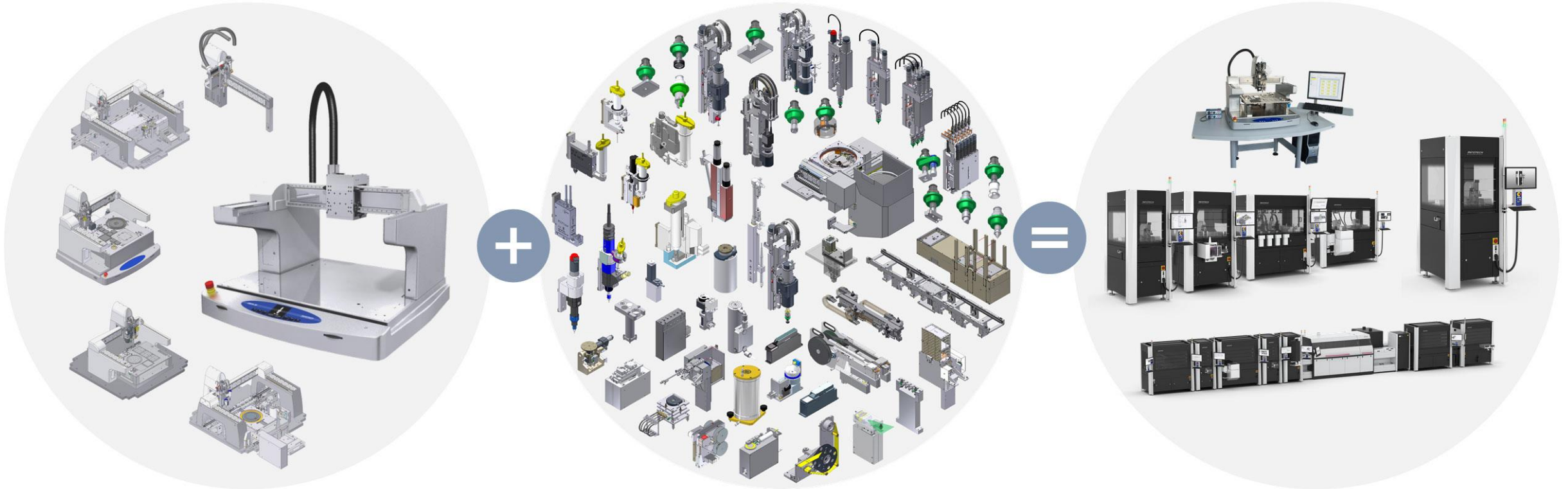

INFOTECH KOMponentenMATRIX



**PRODUKTIONSZELLEN
PLATTFORMEN**



KOPFPERIPHERIEN



TISCHPERIPHERIEN

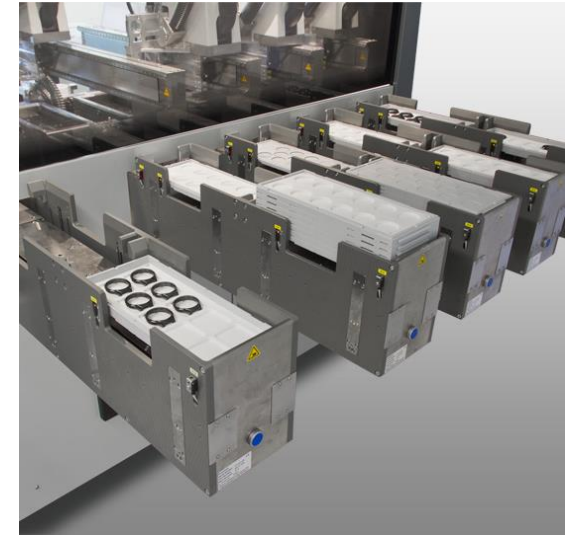

ZUFÜHRPERIPHERIEN



PRODUKTIONSZELLEN

IC-900, IC-1200, IC-1600, IC-1800, IC-2000 und IC-2200



PLATTFORMEN

IP-100



IP-500

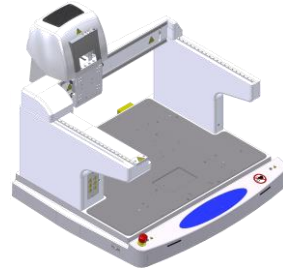

IP-600

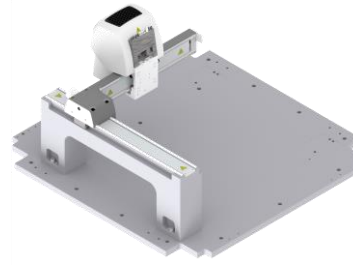

IP-620

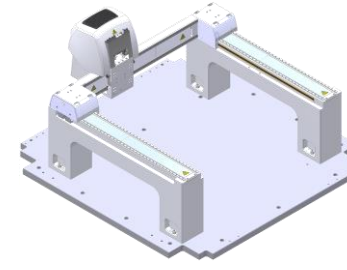

IP-720

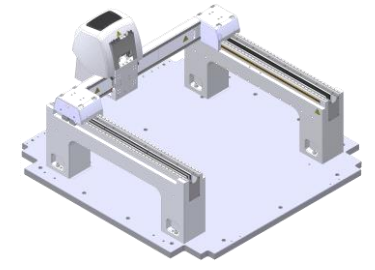

Verfahrweg X	93 – 140 mm	400 mm	210 – 340 mm	210 – 540 mm	210 – 540 mm
--------------	-------------	--------	--------------	--------------	--------------

Verfahrweg Y	440 – 680 mm	400 mm	400 – 730 mm	400 – 730 mm	540 – 730 mm
--------------	--------------	--------	--------------	--------------	--------------



PLATTFORMEN

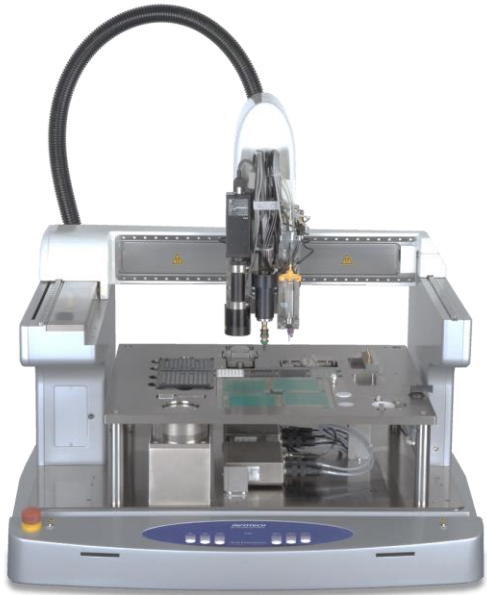

Skalierbar von der Desktop zur Produktionslinie

PLATTFORMEN

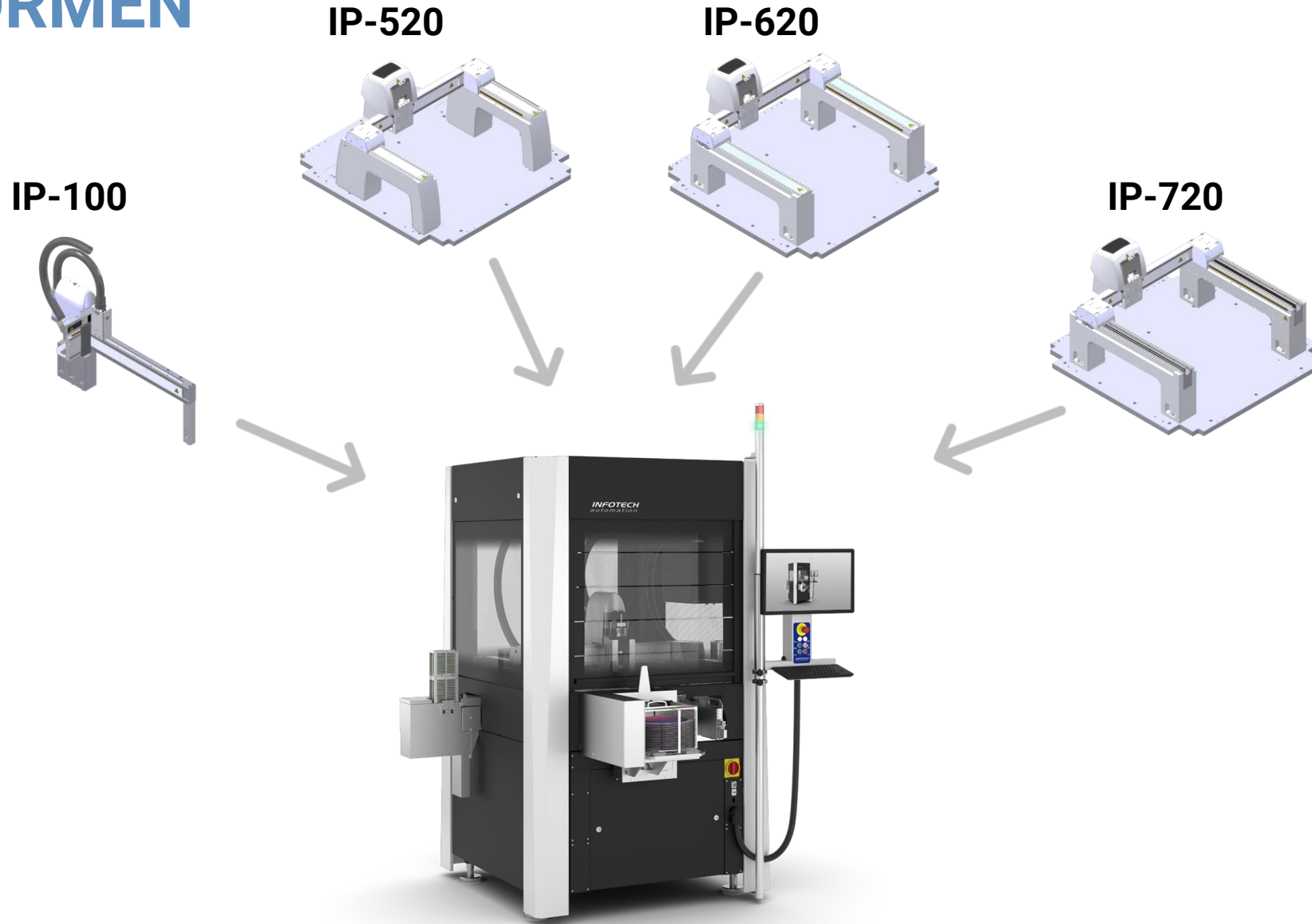

PRODUKTE

KOPFPERIPHERIEN

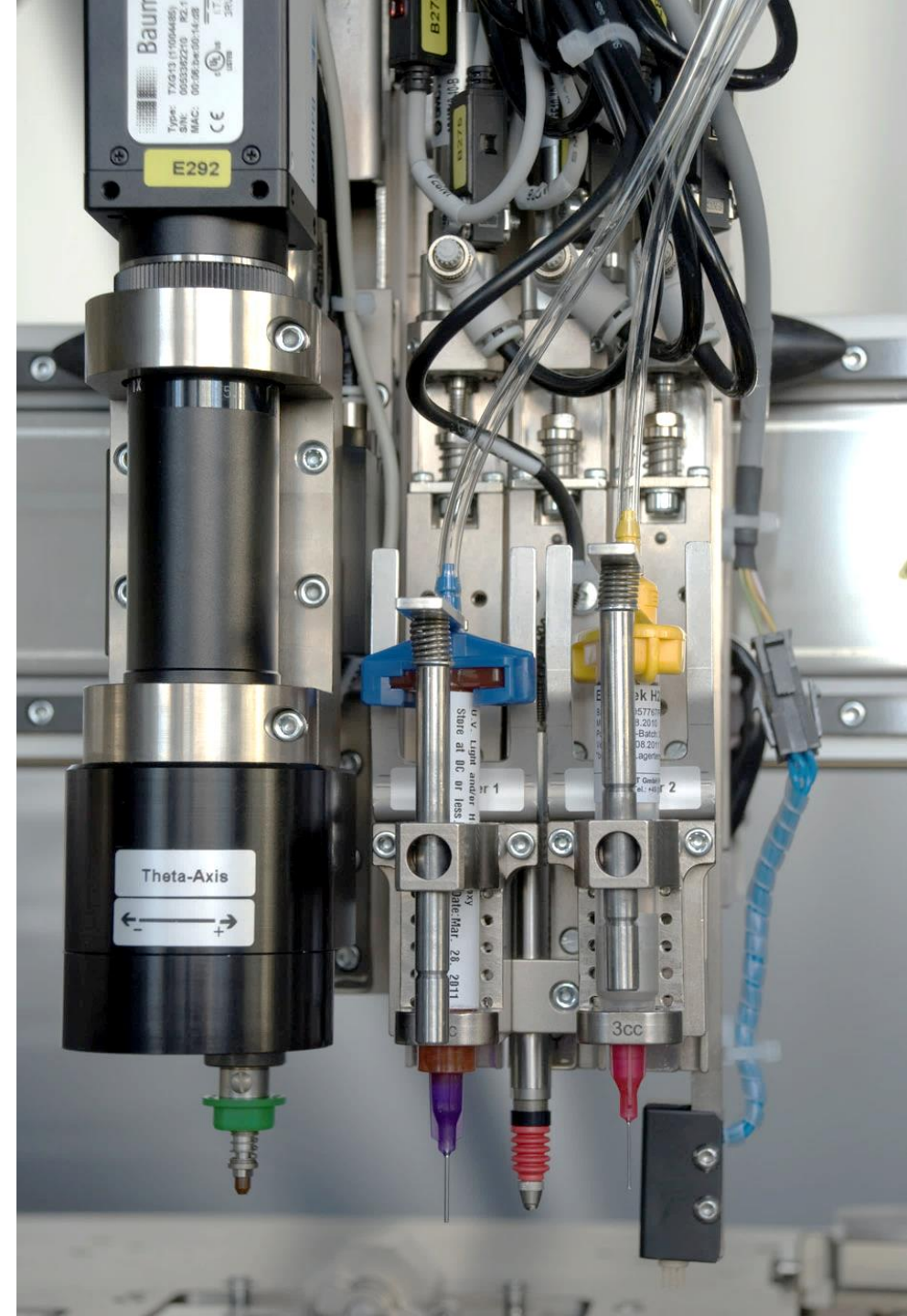
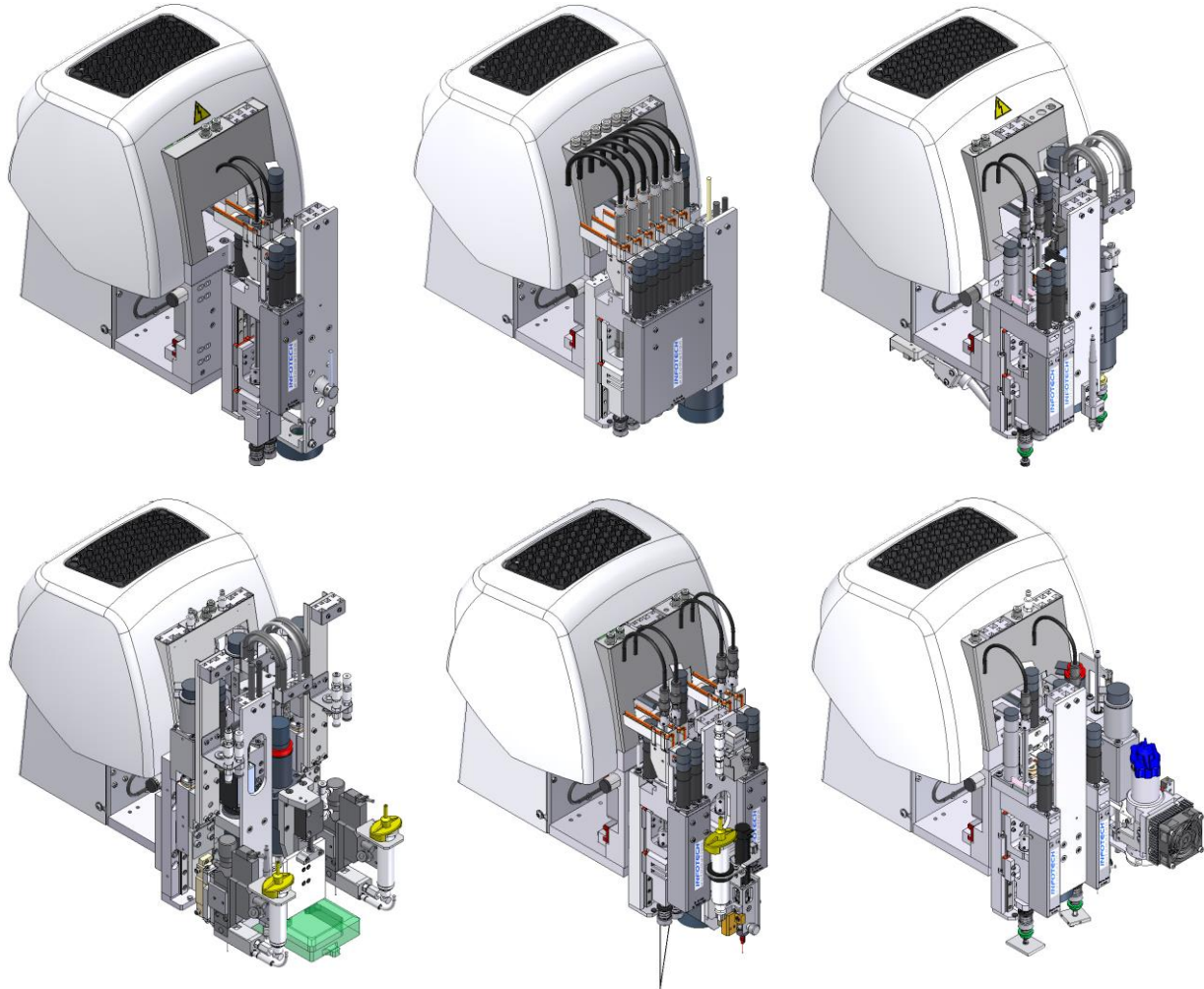

PRODUKTE

TISCHPERIPHERIEN

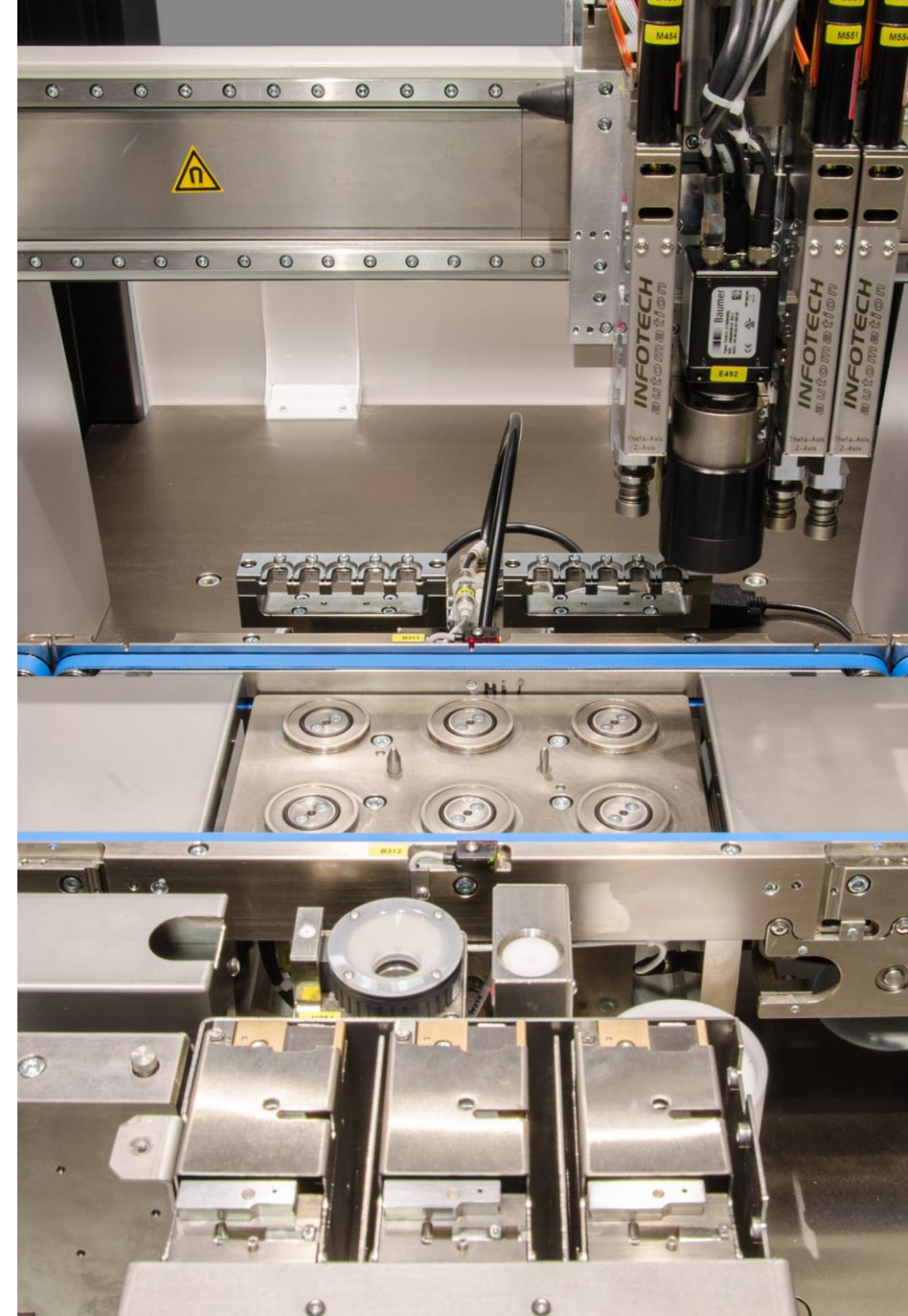
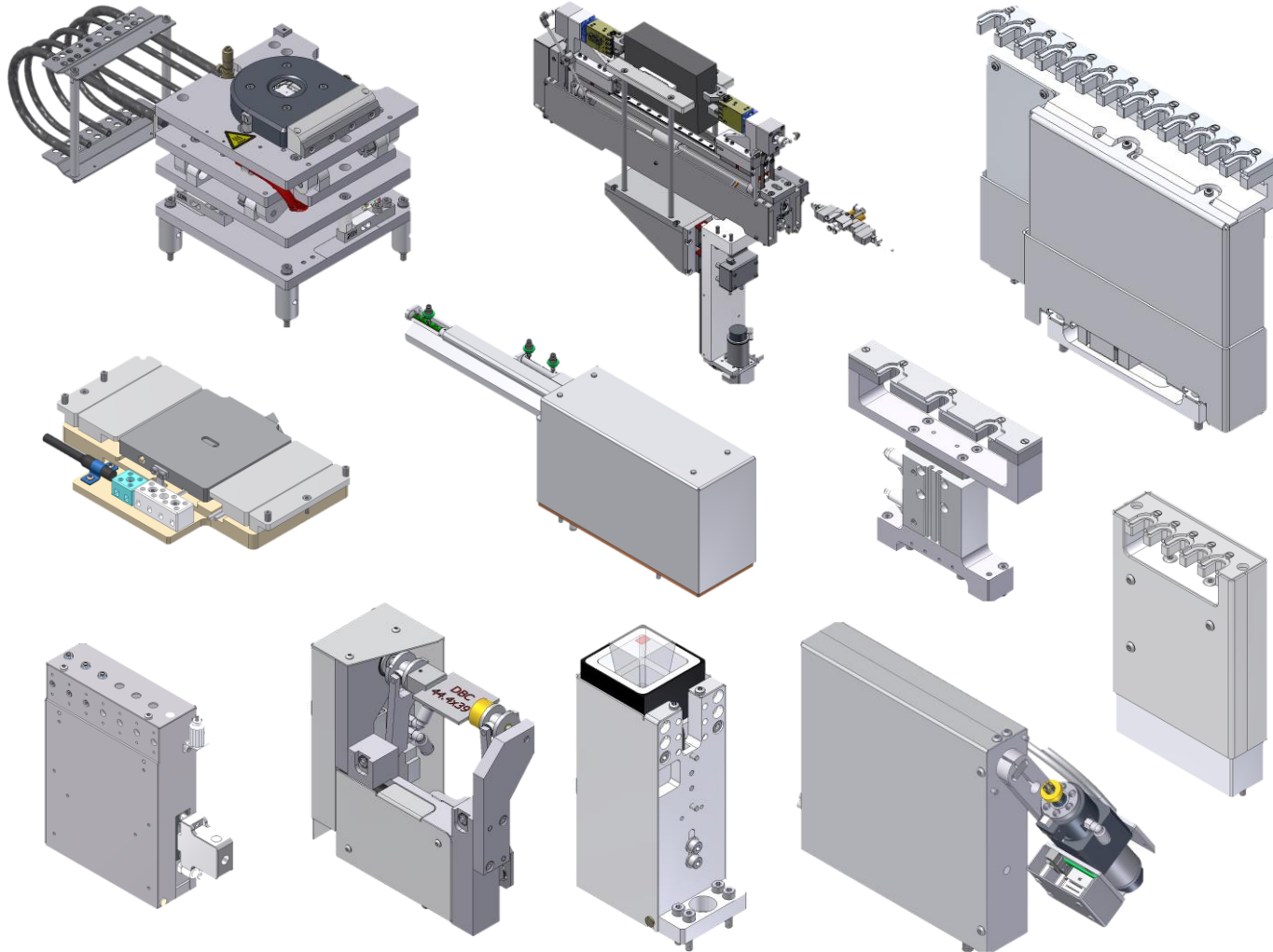

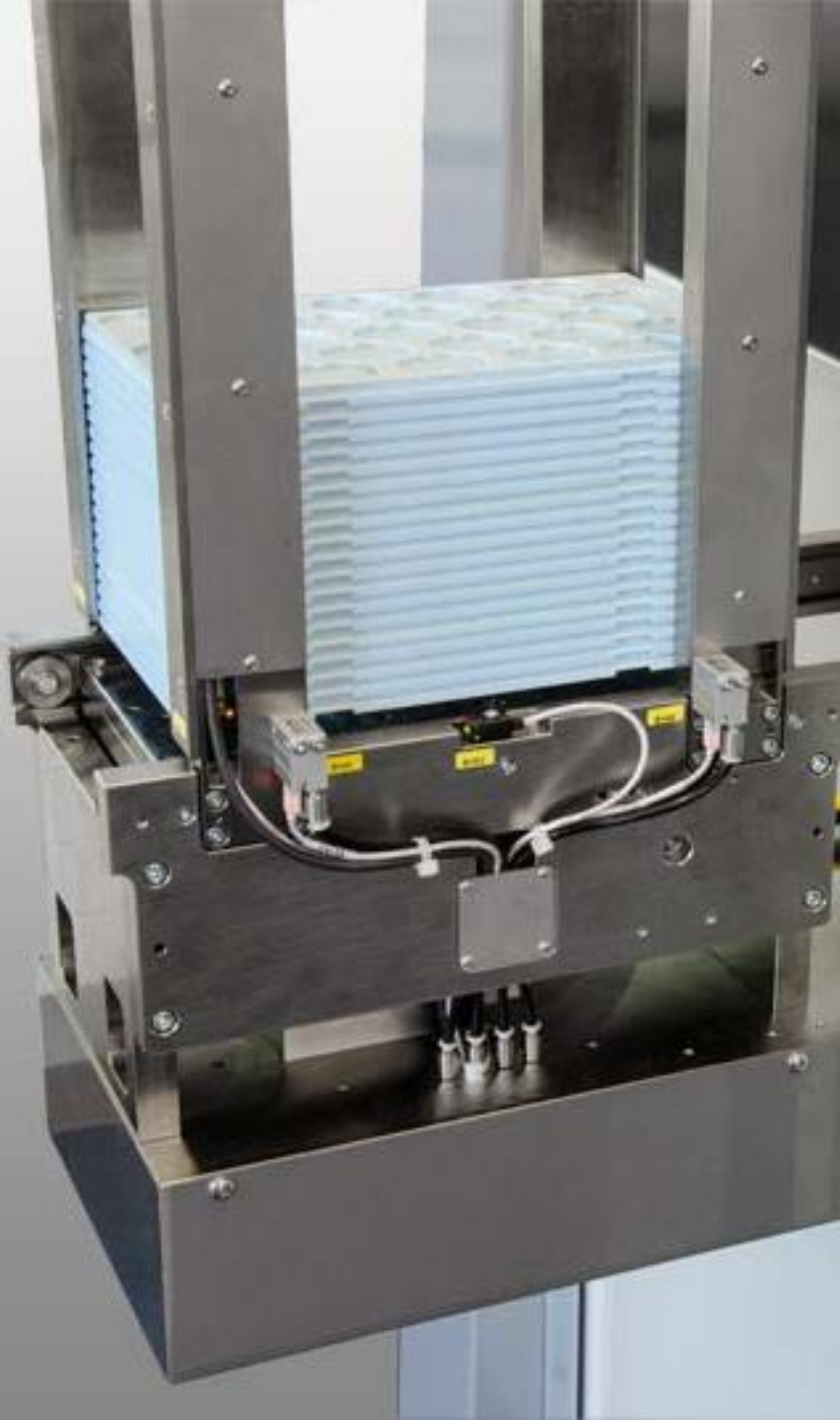

PRODUKTE

INFOTECH
automation

ZUFÜHRPERIPHERIEN

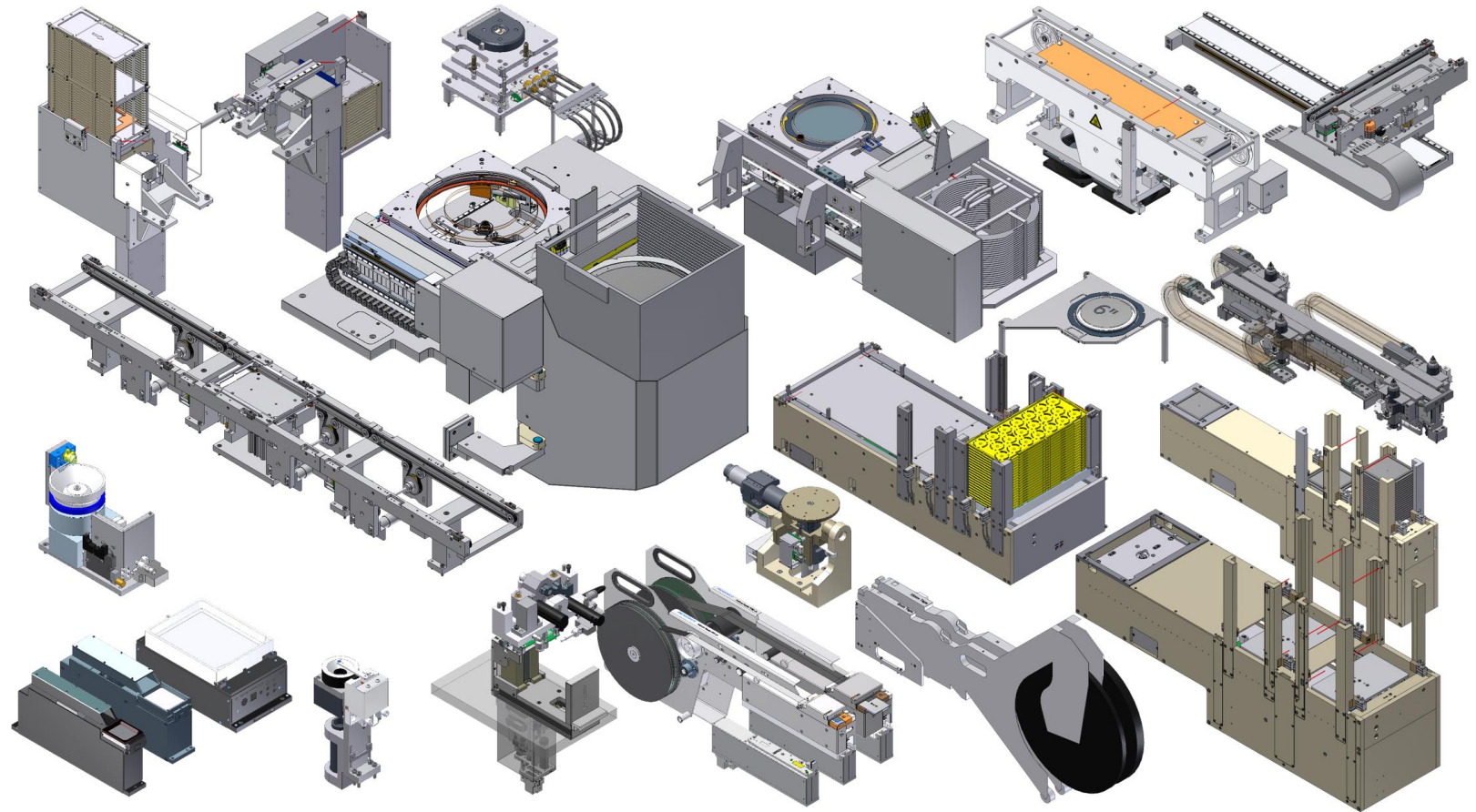

2024

INFOTECH

FIRMEN PRÄSENTATION



- 1 FIRMENÜBERBLICK
- 2 PRODUKTE
- 3 ANWENDUNGSBEISPIELE**

APPLICATIONS

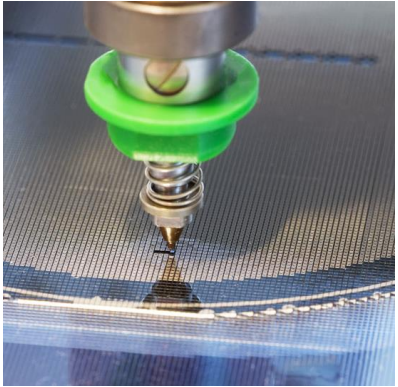

ASSEMBLING

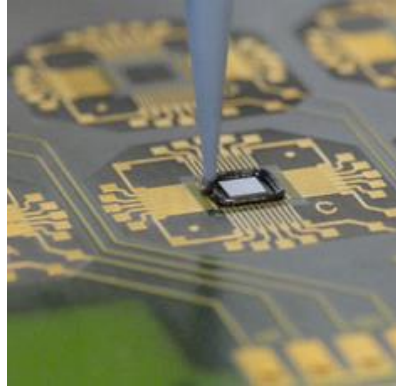

DISPENSING

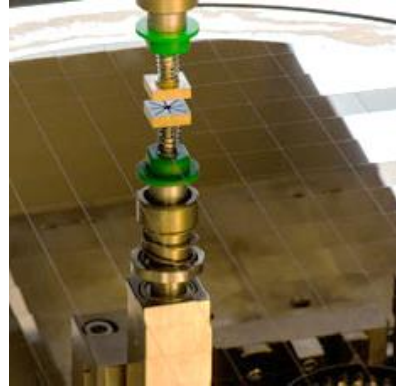

POWER MODULE



SORTING

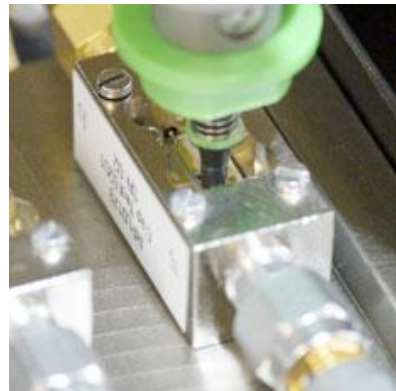

TESTING



PACKAGING



ANWENDUNGSBEISPIELE

BESTÜCKEN

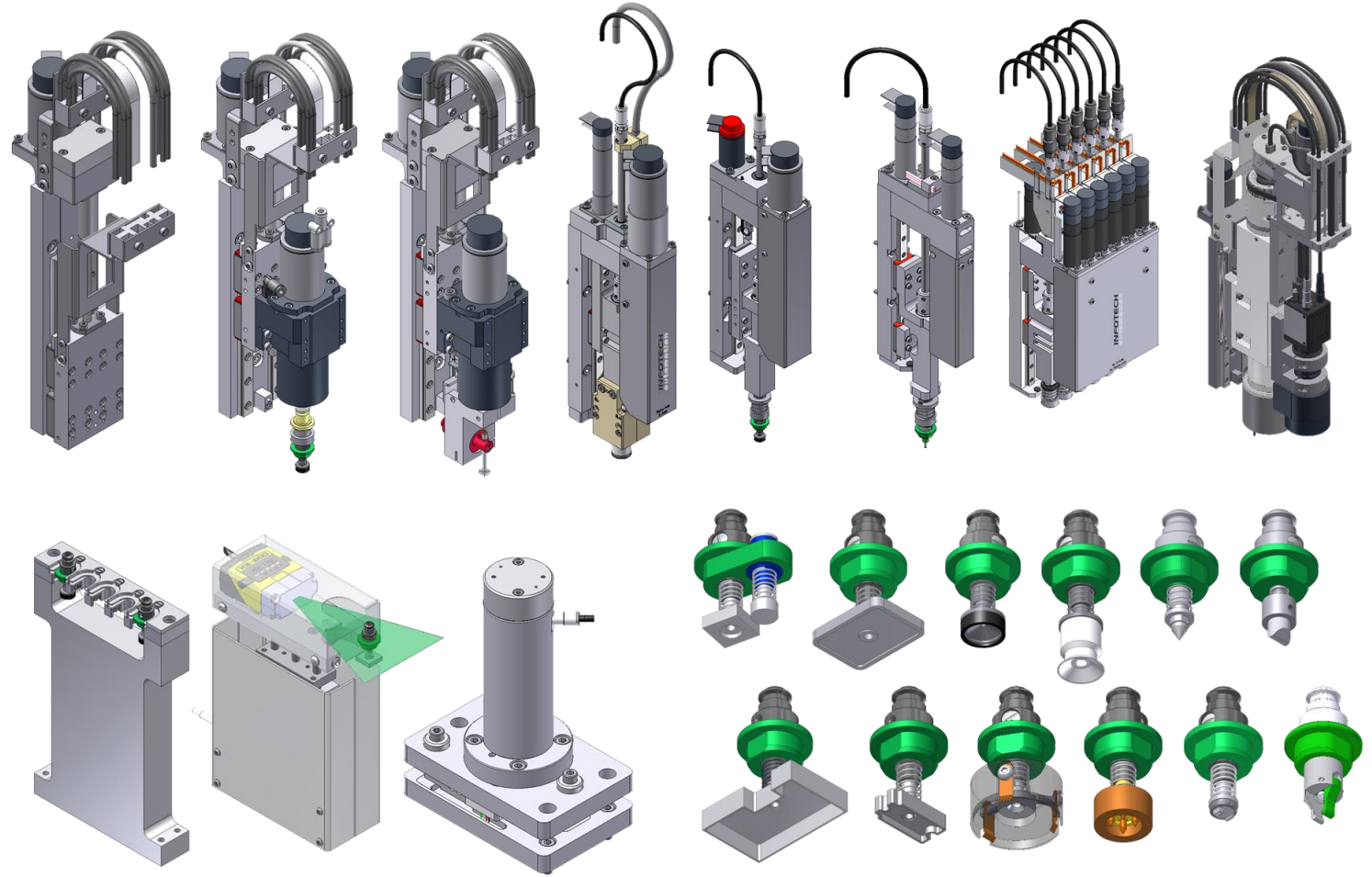

ANWENDUNGSBEISPIELE

DOSIEREN

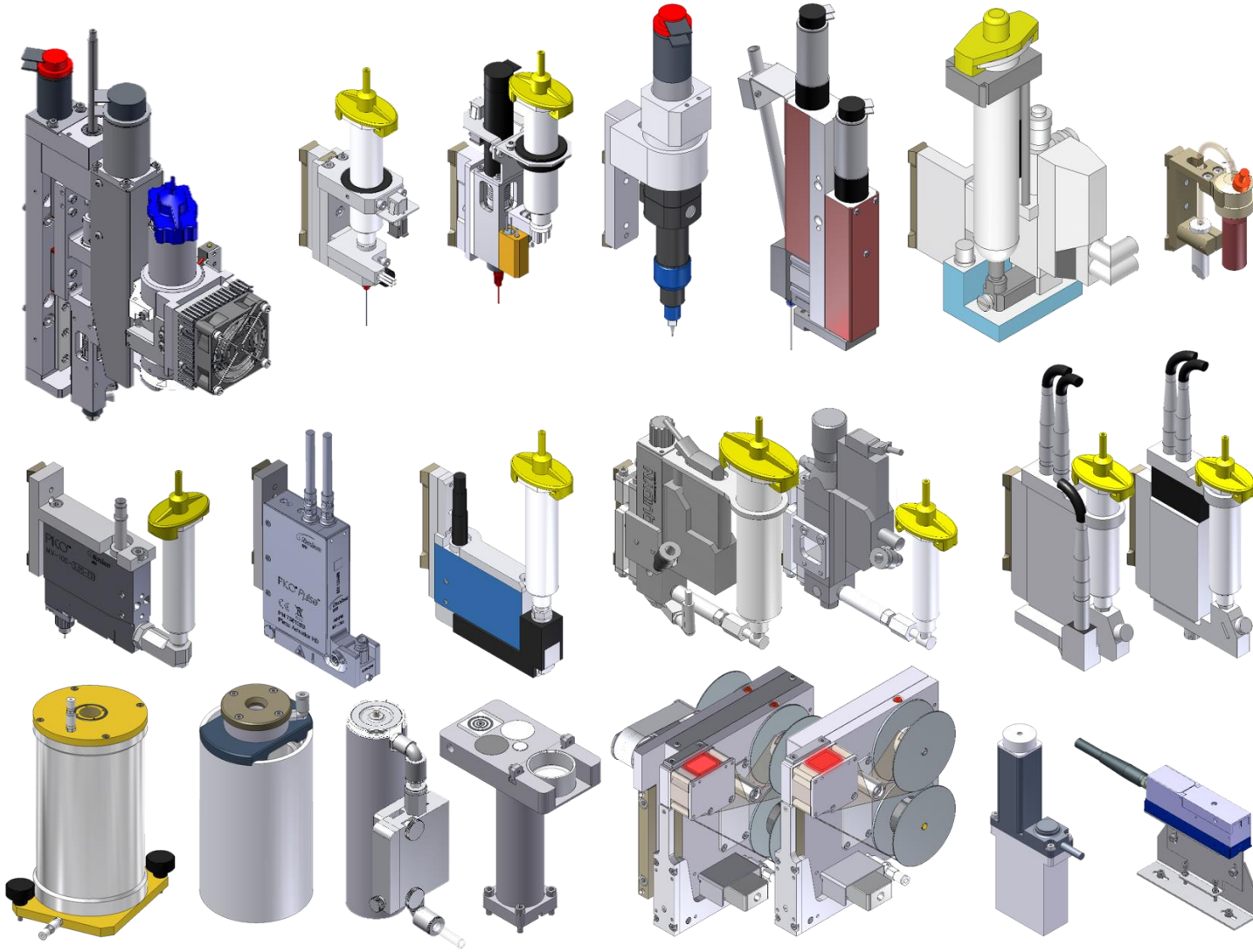

IP-500 DESKTOP

Relative assembly of opto electric transceivers

Relativbestückung von optoelektronischen Transceivern



IP-500 DESKTOP

Dispense-and assembly processes for pressure sensors

Dosier- und Bestückungsprozesse für Drucksensoren



IP-500 DESKTOP

Pre-assembly of optical parts for
solid-state laser

Vorbestückung von optischen
Teilen für Festkörperlaser



IC-900 PREFORM BONDER

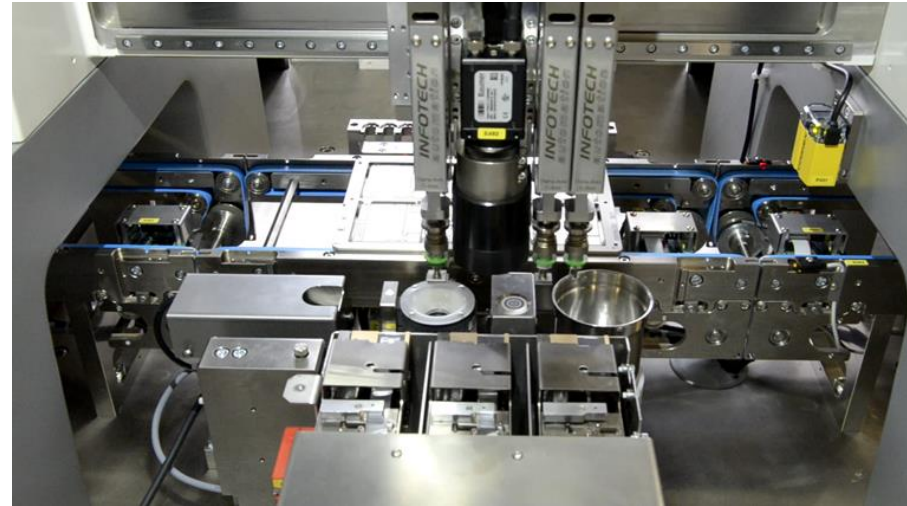

IC-900 Preform bonder with 3 preform feeders
PF2-14 - Cut, pick, inspect and place solder
preform from tape onto DBC-substrates for
power modules

IC-900 Lötfolien Bonder mit 3 Lötfolienzuführungen
PF2-14 Schneiden, aufnehmen, Qualitätskontrolle
und absetzen der Lötfolie auf eine DCB-Substrat für
die Leistungselektronik

IC-900 DOSIERANLAGE



Auf der IC-900 Dosierzelle lassen sich vielfältige Dosierprozesse präzise, schnell und zuverlässig ausführen. Durch die selbstentwickelte Universalschnittstelle lassen sich diverse Dosierventile ohne grossen Rüstaufwand einsetzen.

IC-1200 – DIE BONDER 12" WAFER



Preform and die bonder for power module production with 12" Wafer die eject feeder

Lötfolien und Die Bonder für die Produktion von Modulen für die Leistungselektronik mit 12" Wafer Zuführung und Ausstecheinheit

IC-2200 – DUAL DIE SINTER BONDER 12" WAFER



Dual Sinter Bonder with dual 12"
Wafer die eject feeder and die
tacking process peripherals

IC-2000 - POWER MODULE BONDER 12" WAFER

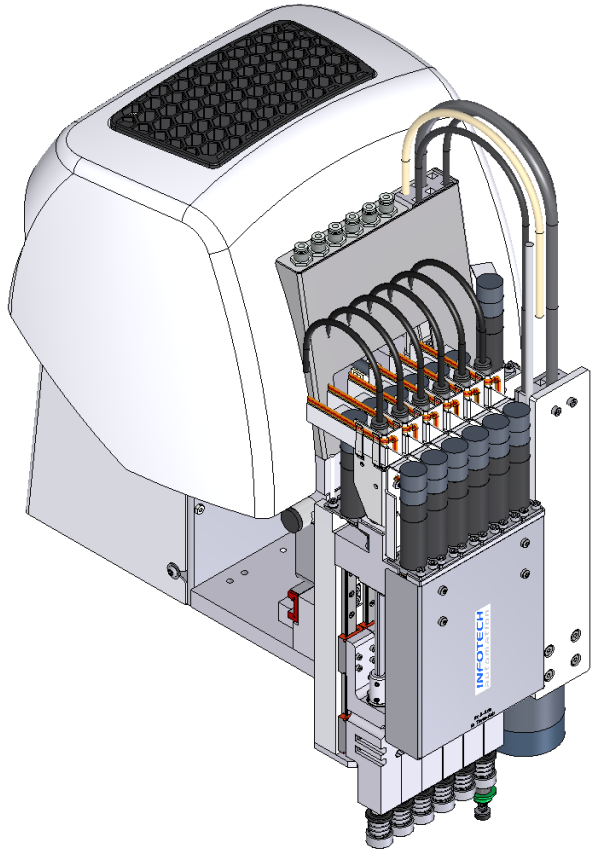

High-speed die bonder for power module production with 12" Wafer die eject feeder and six independent assembly heads

Lötfolien und Die Bonder für die Produktion von Modulen für die Leistungselektronik mit 12" Wafer Die-Eject Zuführung und sechs unabhängigen Bestückungsköpfen



DIE ATTACH FOR SINTER PRODUCTS- LAB EQUIPEMENT

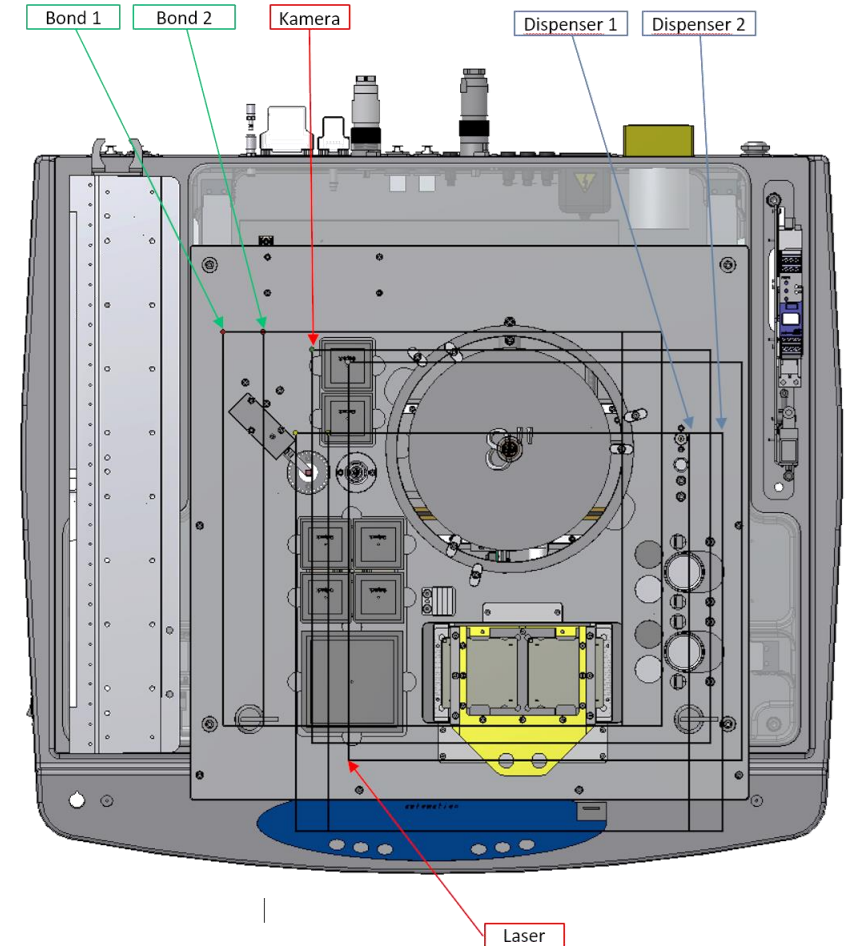
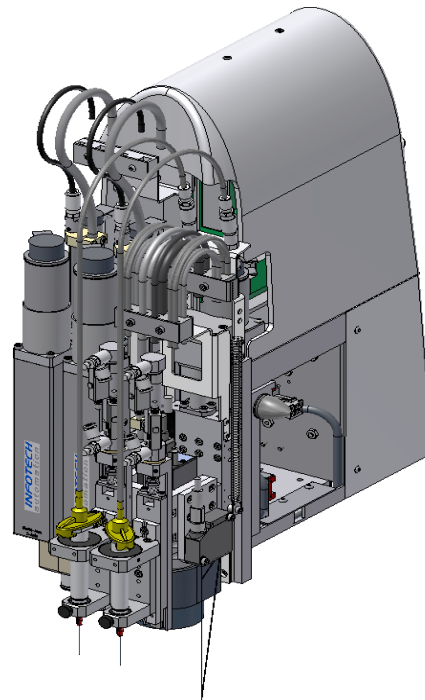
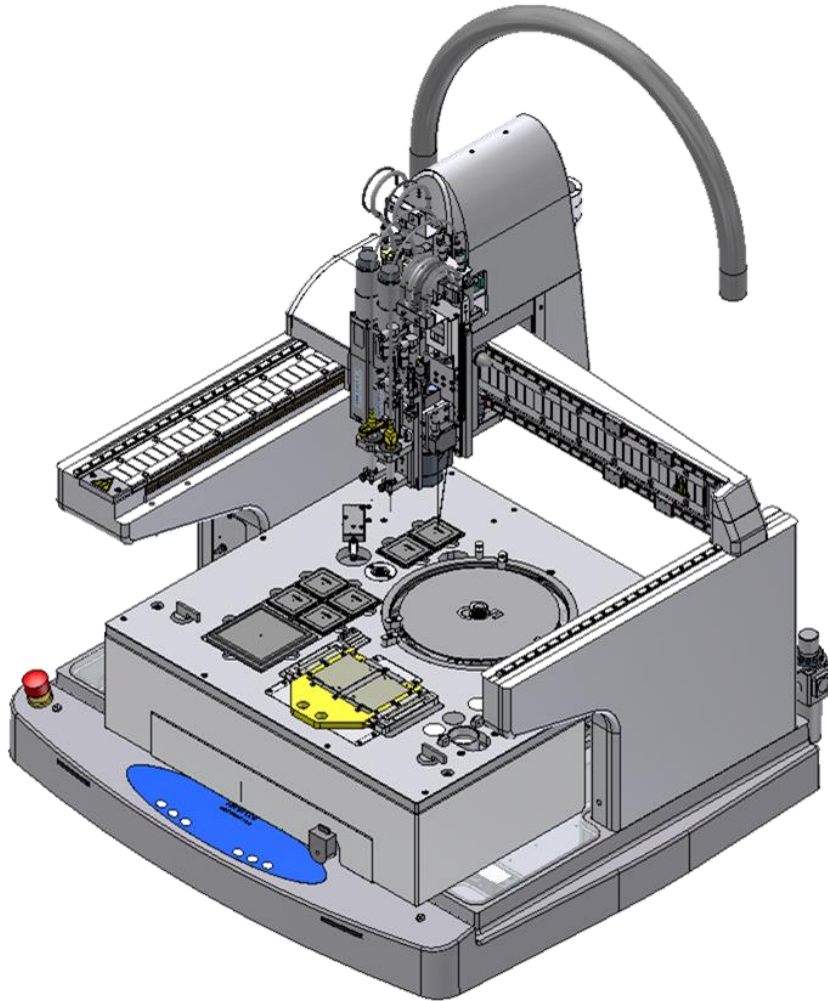

DIE ATTACH FOR SINTER PRODUCTS

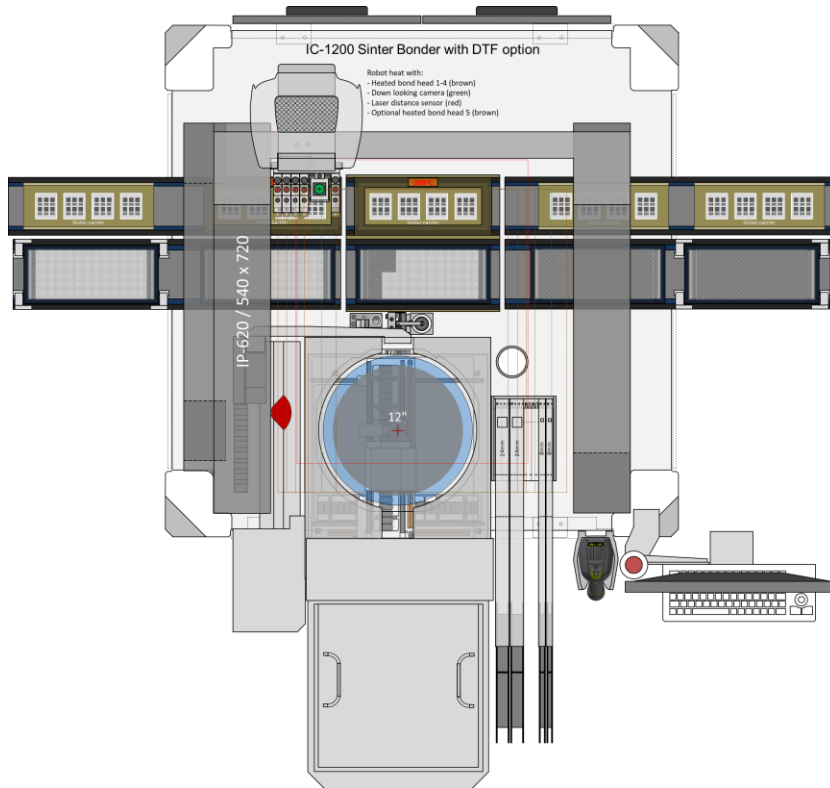

- Heated bond heads up to 3 x 34 mm width heads, or up to 5 x 20 mm heads
- Heated bond head up to 300°C, with manual exchangeable heater bond head tools with bond force capabilities up to 300N
- Optional assembly head with interposer to transfer Die from cold to heated bond head
- Substrate holder plate with manual tilt adjustment, heated surface up to 300°C with integrated force sensor table
- Substrate pre-heat station, heated surface up to 300°C
- Die-, Preform-, Spacer-, DTS-, NTC-, SMD Bonder with sinter tacking option
- Wafer-, Preform-, Tape-, Waffle pack-, loose parts- Feeder
- Dispenser, Flipper, Dip-station and many other options from the Infotech component matrix
- Tacking process into sinter paste, DTF-Process or wafer laminated processes

The highly flexible Die attach power module bonder is used for various production demands from laboratory up to series production.

DIE ATTACH FOR SINTER PRODUCTS

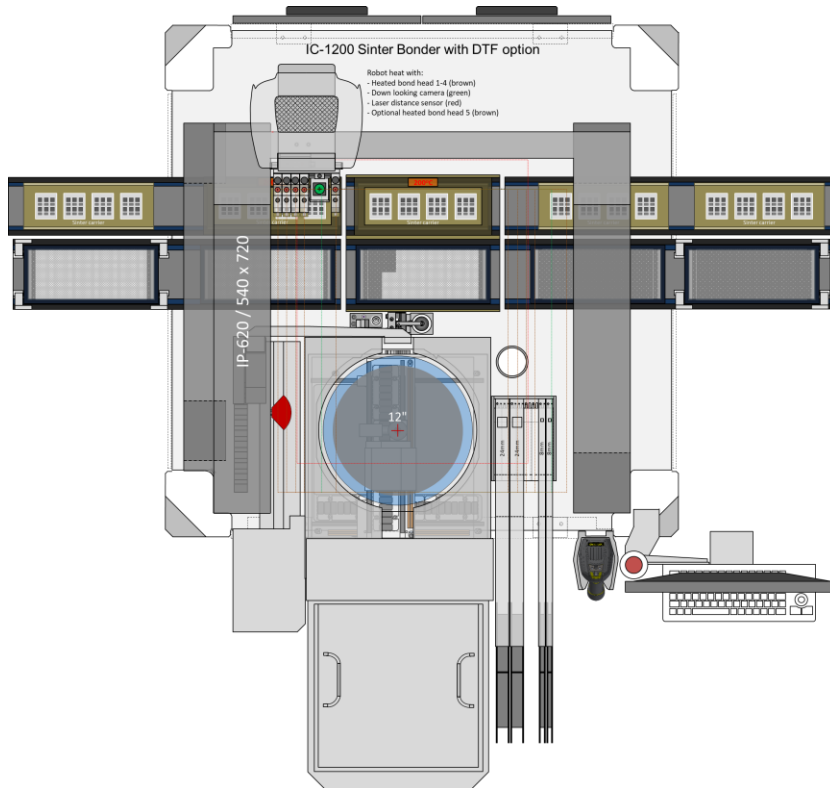

DTF with Tacking process

Supports DTF process (Die Transfer Film - Alpha Assembly Solutions) from 4x4" size, Jedec size or wafer frame size

- Loading and pre-heating substrates
- Die recognition on wafer / waffle pack / Tape (ink dot, alignment) using upper vision, or using wafer map
- Pickup Die with heated bond head
- Transfer film to Die with force feedback
- Die alignment and quality inspection of sinter foil on Die using lower vision
- Verify substrate temperature
- Tack on heated substrate with heated bond head and force sensing
- Unloading of substrates

The highly flexible Die attach power module bonder is used for various production demands from laboratory up to series production.

IC-1800 CHAIN ASSEMBLY



Chainsaw Bosch

Sorting of 4 parts building the chain, assembly, 3D-inspection and grouting of chain

Bosch Kettensäge

Sortieren von 4 Teilen zur Montage der Kette, bestücken, visuelle 3D- Kontrolle, und verpressen der Teile zur Kette



IC-1200



Pharma assembly line:

3X IC-1200 / 2x IP-520 / 4x IP-100

Precision membrane assembly of a valve for asthma spray

Pharmamontagelinie:

3X IC-1200 / 2x IP-520 / 4x IP-100

Präzision-Membranbestückung in einem Ventil für einen Asthmaspray

FC-1600 WATCH PRODUCTION LINE

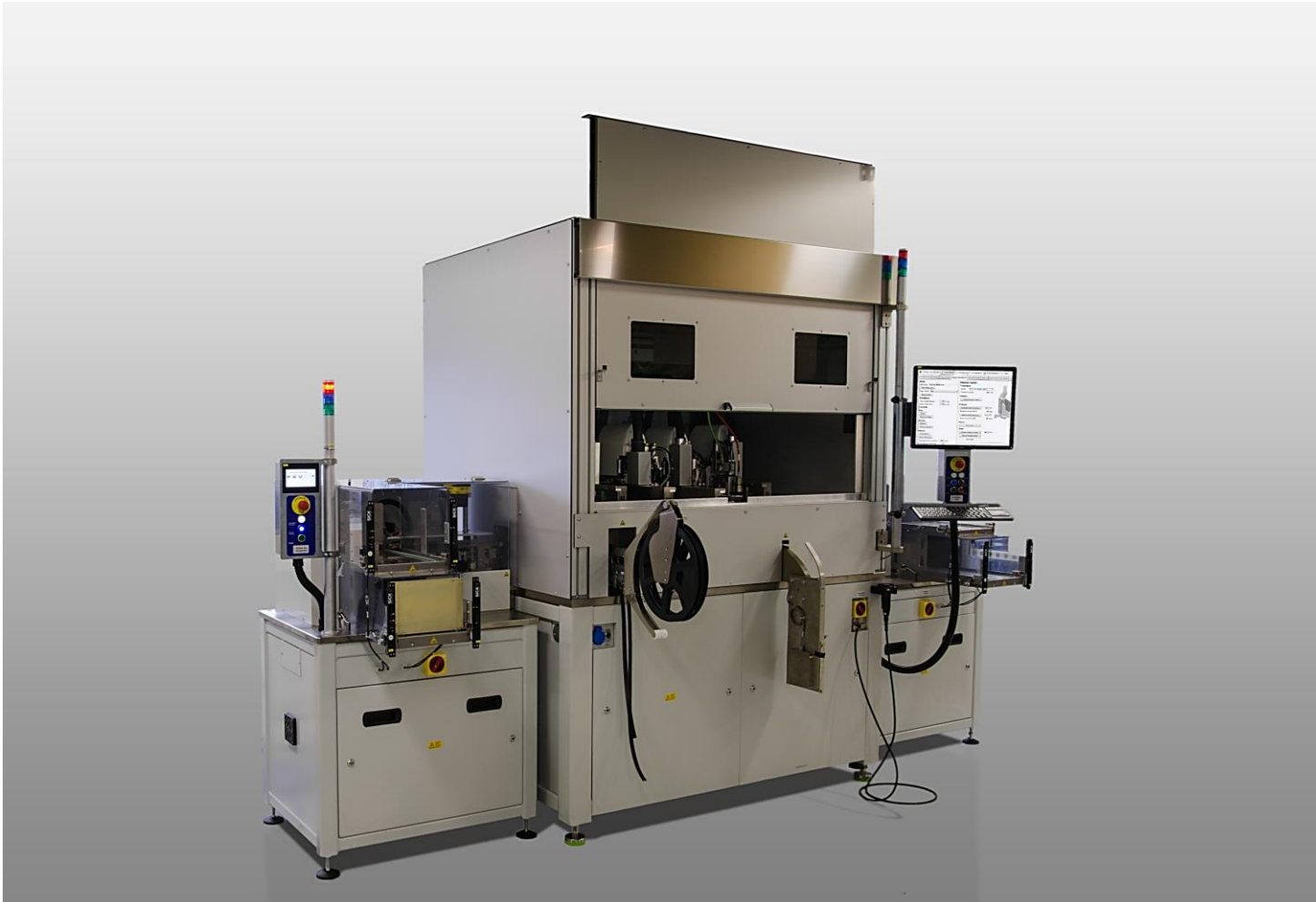

Watch assembly (Swatch):

- 2X FC-1600 / 5X IP-100 / 1X IP-520
- Assembling and soldering of pcb onto leadframe
Welding of quartz onto leadframe
- Cut, test and sort into output tray

Uhrenmontage (Swatch):

- 2X FC-1600 / 5X IP-100 / 1X IP-520
- Bestücken und löten eines Elektronikbauteils
- Bestücken und schweissen eines Quarzes
- Schneiden, testen und ablegen in Ausgangstray

WATCH ASSEMBLY LINE



28 IC-1000 / 28 IP-520 / 10 IP-100 SWATCH
SYSTEM51

First fully automatic production line with
complete assembly and functional test of
mechanical watch SYSTEM51 of Swatch

Erste vollautomatisch Produktionslinie zur
vollständigen Montage des mechanischen
Uhrwerks SYSTEM51 von Swatch

DBC PRODUCTION LINE



Fully automatic DBC production line using flux free soldering including laser marking, automatic material loading and unloading using AGV systems

Vollautomatische DBC (Substrat) Produktionsanlage zum flussmittelfreien Löten, mit Lasermarkierung und voll automatischem Material zu- und wegführen mittels AGV (Autonomous guided vehicles)

TYPICAL POWER MODULE PRODUCTION LINE

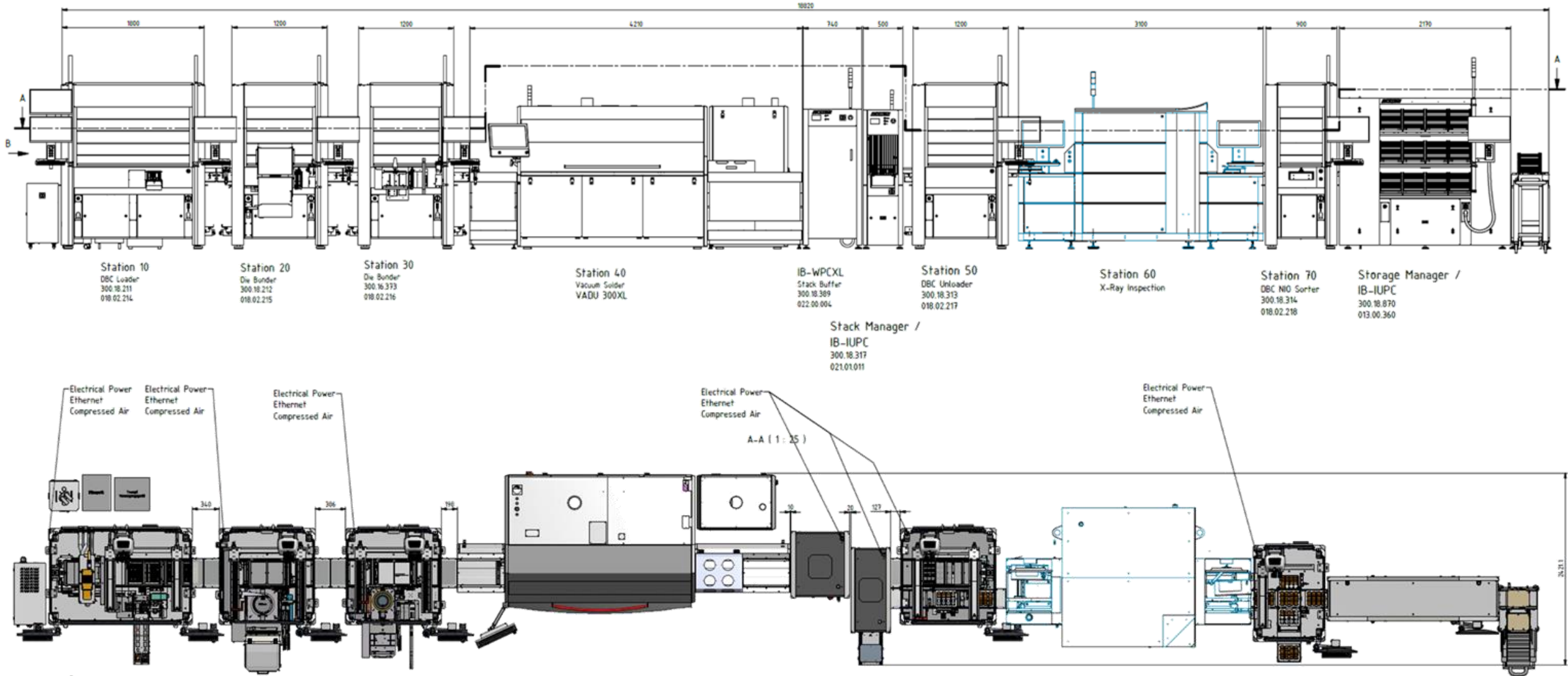

POWER DIODE PRODUCTION LINE



- Carrier lift to upper conveyor
- Heat sink mounter
- Preform attacher
- Die bonder
- Preform attacher
- Head wire mounter

- Vacuum oven

- Stacker
- Power diode unloader
- Carrier lift to lower conveyor
- Gel dispenser
- Electrical tester
- Unloader



INFOTECH
automation

Exceeding your expectations